



# WA55-1520A

## 5.0- 6.0 GHz LOW NOISE WIDE BAND AMPLIFIER

REV B  
January 2016

### Key Features



- 50 Ohm Impedance
- 5.0 - 6.0 GHz
- 1.0 dB Noise Figure
- 22.0 dBm Output  $IP_3$
- 15.0 dB Gain
- +/-0.2 dB Gain Flatness
- 12.0 dBm  $P_{1dB}$
- 1.35:1 VSWR
- Single Power Supply
- >34 Years MTBF
- Unconditional Stable
- RoHS compliant

### Product Description

WA55-1520A is integrated with WanTcom proprietary low noise amplifier technology, high frequency micro electronic assembly techniques, and high reliability design to realize optimum low noise figure, wideband, high linearity, and unconditional stable performances together. With single +5.0V DC operation, the amplifier has optimal input and output matching in the specified frequency range at 50-Ohm impedance system. The amplifier has standard SMA connectorized WP-6 Gold plated housing.

The amplifier is designed to meet the rugged standard of MIL-STD-202g.



### Applications

- Mobile Infrastructures
- WiMax
- Defense
- Security System
- Measurement
- Fixed Wireless



### Specifications

Summary of the electrical specifications WA55-1520A at room temperature

Index	Testing Item	Symbol	Test Constraints	Min	Nom	Max	Unit
1	Gain	$S_{21}$	5.0 - 6.0 GHz	14	15	16	dB
2	Gain Variation	$\Delta G$	5.0 - 6.0 GHz		$\pm 0.2$	$\pm 0.5$	dB
3	Input Return Loss	$S_{11}$	5.0 - 6.0 GHz	16	18		dB
4	Output Return Loss	$S_{22}$	5.0 - 6.0 GHz	16	18		dB
5	Reverse Isolation	$S_{12}$	5.0 - 6.0 GHz	20	23		dB
6	Noise figure	NF	5.0 - 6.0 GHz		1.0	1.2	dB
7	Output Power 1dB Compression Point	$P_{1dB}$	5.0 - 6.0 GHz	10	12		dBm
8	Output-Third-Order Interception Point	$IP_3$	Two-Tone, $P_{out}$ +0 dBm each, 1 MHz separation	20	22		dBm
9	Current Consumption	$I_{dd}$	$V_{dd} = +5 V$	40	45	50	mA
10	Power Supply Voltage	$V_{dd}$	WA55-1520F	+4.7	+5	+5.3	V
11	Thermal Resistance	$R_{th,c}$	Junction to case			215	$^{\circ}C/W$
12	Operating Temperature	$T_o$		-40		+85	$^{\circ}C$
13	Maximum CW RF Input Power	$P_{IN, MAX}$	5.0 - 6.0 GHz			13	dBm

### Absolute Maximum Ratings

Parameters	Units	Ratings
DC Power Supply Voltage	V	6.0
Drain Current	mA	70
Total Power Dissipation	mW	350
CW RF Input Power	dBm	13
Channel Temperature	$^{\circ}C$	150
Storage Temperature	$^{\circ}C$	-165 ~ 150
Operating Temperature	$^{\circ}C$	-155 ~ 100
Thermal Resistance	$^{\circ}C/W$	220

Operation of this device above any one of these parameters may cause permanent damage.

### Functional Block Diagram

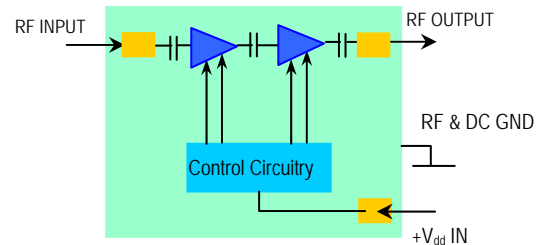

### Ordering Information

Model Number	Feature
WA55-1520A	$V_{dd} = +5.0V$

Specifications and information are subject to change without notice.



# WA55-1520A

## 5.0- 6.0 GHz LOW NOISE WIDE BAND AMPLIFIER

REV B  
January 2016

### Typical Data

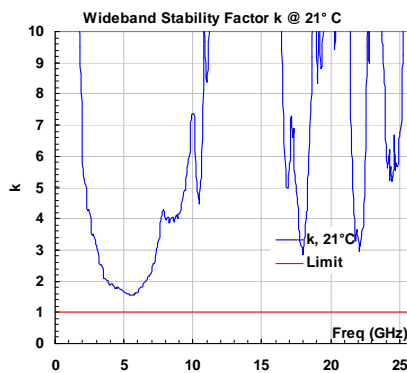
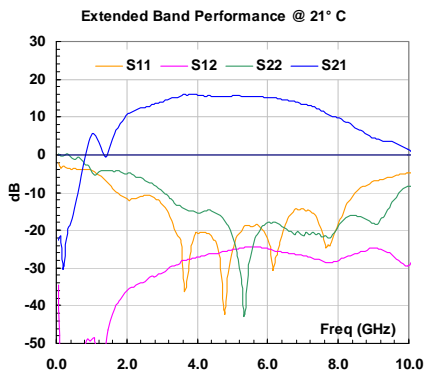
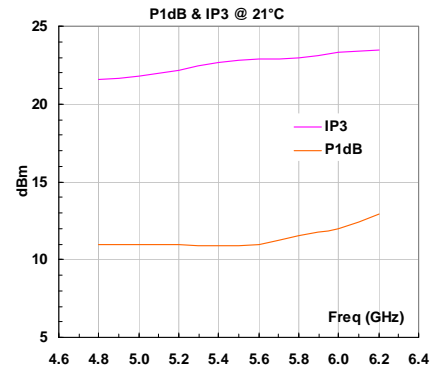
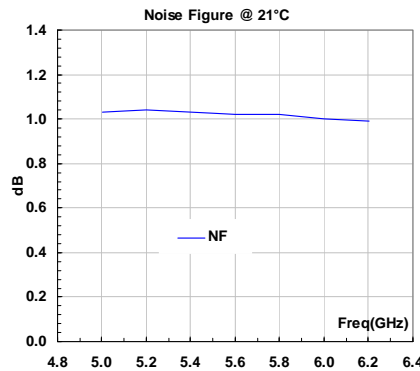
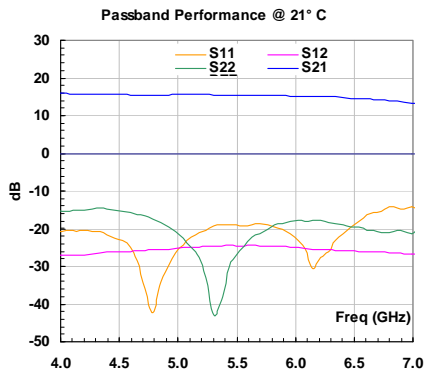

### Outline, WP- 6 Housing

UNITS: INCH  
BODY: Brass  
Finish: Gold Plating  
RF Connector: SMA F Gold  
V<sub>dd</sub> PWR: Feed through

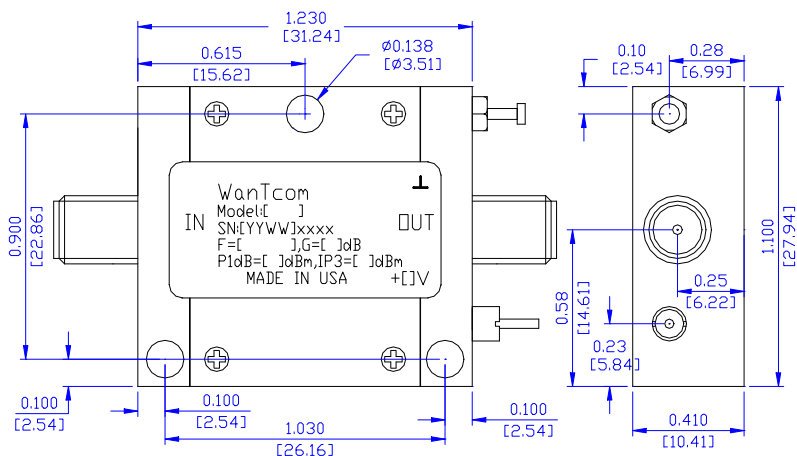

Specifications and information are subject to change without notice.

WanTcom, Inc \* Phone 01 952 448 6088 \* FAX: 01 952 448 7188 \* e-mail: [sales@wantcominc.com](mailto:sales@wantcominc.com) \* Web site: [www.wantcominc.com](http://www.wantcominc.com)



### Application Notes:

#### A. SMA Torque Wrench Selection

Always use a torque wrench with 5 ~ 6 inch-lb coupling torque setting for mating the SMA cables to the amplifier. Never use torque more than 8 inch-lb wrench for tightening the mating cable to the connector. Otherwise, the permanent damage will occur to the SMA connectors of the amplifier. 8710-1582 (5 inch-lb) is one of the ideal torque wrench choice from Agilent Technology.

#### B. DC Power Line Connection

Strip the insulation layer at the end of DC power supply wire. The stripped distance should be in the range of 0.100" to 0.200". The 24 ~ 26 American Wire Gauge wire is suitable. Wound the stripped terminal wire about 1 to 2 turns on the DC feed thru center pin. Solder the wounded wire and the center pin together. Clean the soldering area by Q-tip with alcohol to remove the flux and residue.

Repeat the process to solder the DC return wire on the ground turret.

#### C. Mounting the Amplifier

Use three pieces of #4-40 with longer than 9/16" screws for mounting the amplifier on a metal-based chase. Flat and spring washers are needed to prevent the screw loosening during the shock and vibration. Always use the appropriate torque setting of the power screwdriver to mount them.

\*\*\*\*\*