



WHM2540AE

2.5 – 4.0 GHz LOW NOISE WIDE BAND AMPLIFIER

REV E
February 2017

Key Features



- 2.5 ~ 4.0 GHz
- **0.80 dB Noise Figure**
- 24.0 dBm output IP₃
- 28.0 dB Gain
- 10.0 dBm P_{1dB}
- 1.5:1 VSWR
- Single Power Supply
- RoHS Compliant
- Unconditional Stable, $k > 1$
- RoHS Compliant
- MSL-1 Moisture Sensitivity Level

Product Description

WHM2540AE is integrated with WanTcom proprietary low noise amplifier technologies, high frequency micro electronic assembly techniques, and high reliability designs to realize optimum low noise figure, wideband, and high performances together. With single +5.0V DC low power operation, the amplifier has optimal input and output matching in the specified frequency range at 50-Ohm impedance system. The amplifier has standard 0.25" x 0.35" x 0.08" surface mount package.

The amplifier is designed to meet the rugged standard of MIL-STD-883g.

CAUTION:



ELECTROSTATIC DISCHARGE SENSITIVE

Applications

- Mobile Infrastructures
- ViMAX
- Defense
- Security System
- Measurement
- Fixed Wireless

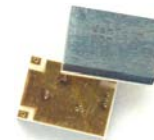

Specifications

Summary of the key electrical specifications at room temperature

Index	Testing Item	Symbol	Test Constraints	Min	Nom	Max	Unit
1	Gain	S ₂₁	2.5 – 4.0 GHz	26	28	30	dB
2	Gain Variation	ΔG	2.5 – 4.0 GHz		+/- 0.5	+/- 1.0	dB
3	Input VSWR	SWR ₁	2.5 – 4.0 GHz		1.35:1	1.5:1	Ratio
4	Output VSWR	SWR ₂	2.5 – 4.0 GHz		1.5:1	1.8:1	Ratio
5	Reverse Isolation	S ₁₂	2.5 – 4.0 GHz		40		dB
6	Noise Figure	NF	2.5 – 4.0 GHz		0.80	0.90	dB
7	Output Power 1dB Compression Point	P _{1dB}	2.5 – 4.0 GHz	8	10		dBm
8	Output-Third-Order Interception Point	IP ₃	Two-Tone, P _{out} = 0 dBm each, 1 MHz separation		24		dBm
9	Current Consumption	I _{dd}	V _{dd} = +5 V	40	45	50	mA
10	Power Supply Operating Voltage	V _{dd}		+4.7	+5.0	+5.3	V
11	Thermal Resistance	R _{th,c}	Junction to case			110	°C/W
12	Operating Temperature	T _o		-40		+85	°C
13	Maximum Input CW RF Power	P _{IN, MAX}	DC – 6.0 GHz			10	dBm
14	Spurious	P _{spur}	DC – 13 GHz, P _{out} = 0 dBm Single tone	-70			dBc

Absolute Maximum Ratings

Parameters	Units	Ratings
DC Power Supply Voltage	V	-0.5, 7.0
Drain Current	mA	70
Total Power Dissipation	mW	400
Input CW RF Power	dBm	10
Channel Temperature	°C	150
Storage Temperature	°C	-65 ~ 150
Operating Temperature	°C	-54 ~ +100
Thermal Resistance	°C/W	220

Operation of this device beyond any one of these parameters may cause permanent damage.

Ordering Information

Model Number	WHM2540AE
--------------	-----------

ESD tube is used for the packing. Contact factory for tape and reel packing option for higher volume order.

Specifications and information are subject to change without notice.

Functional Block Diagram

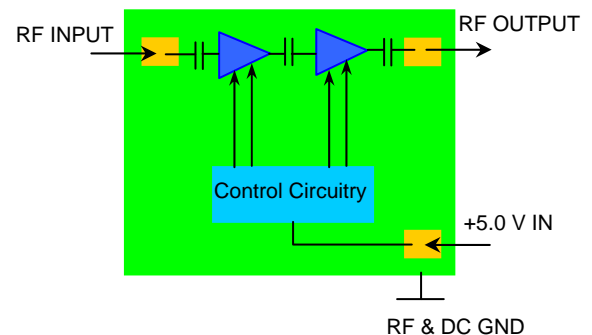



Typical Data

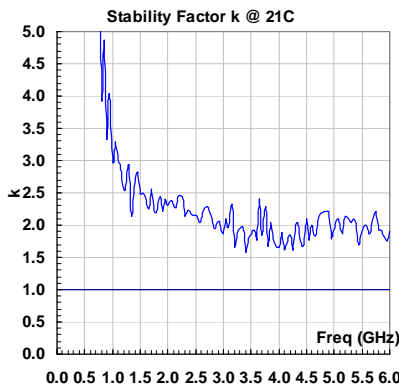
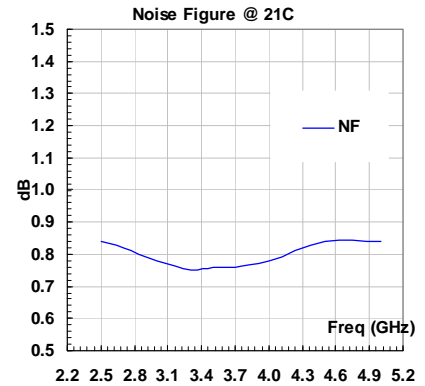
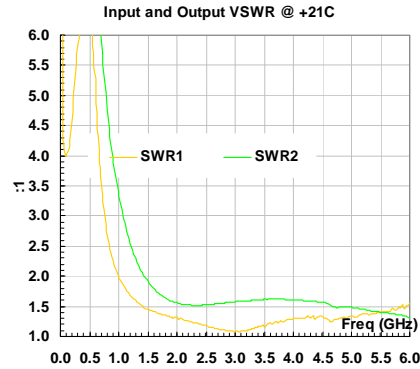
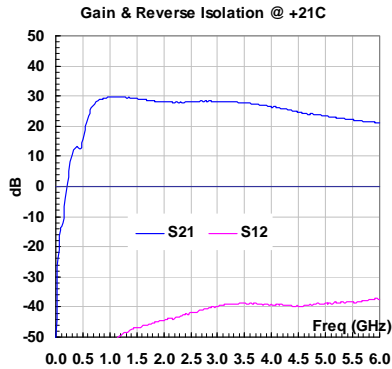

Outline, WHM-5

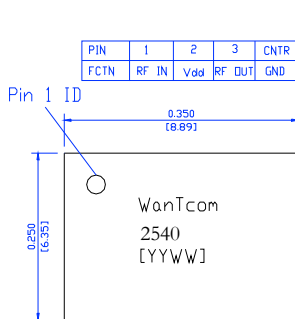

UNITS: INCH Tolerance: X.XXX +/- 0.005"
[mm] X.XXXX +/- 0.003"
FINISH: 0.000010" MAX EMERSION GOLD PLATING.

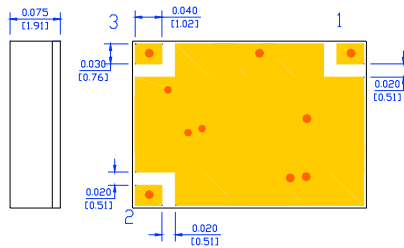

Foot Print/Mounting Layout

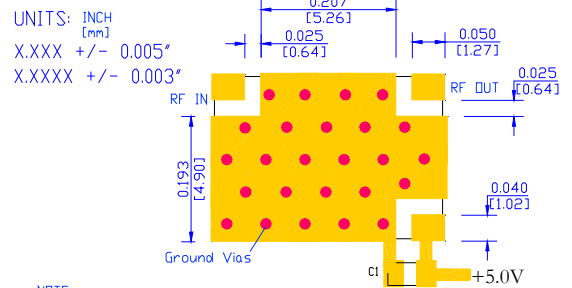

- NOTE:
1. THE BACKSIDE NEEDS TO BE METAL GROUND LAYER
 2. GROUND VIA DIAMETER IS 0.016" (0.41 mm);
 3. MATERIAL: FR-4, N4000-13, FROM NELCO
 4. USE PROPER WIDTH FOR 50-OHM LINES FOR OTHER PCB MATERIAL
 5. C1: 0.01uF, X7R, Ceramic



Application Notes:

A. Motherboard Layout

The recommended motherboard layout is shown in **Fig. 1**. Sufficient numbers of ground vias on the center pad are essential for the RF grounding and LNA heat dissipation. The width of the 50-Ohm microstrip lines at the input and output RF ports may be different for different property of the PCB substrate. The ground plane on the backside of the PCB substrate is needed to connect the center ground pad through the vias. The ground plane is also essential for the 50-Ohm microstrip line launches at the input and output ports.

The +5V DC voltage is applied to Pin 2 of the LNA. For +5V line trace length being longer than 6 inches without a decoupling capacitor, a 0.10 uF de-coupling capacitor, C₁, with minimum rating voltage of 10V is needed across the +5V pin to ground. The capacitor must be rated in the temperature range of -55 °C to 100 °C to ensure the entire circuit work in the specified temperature range.

No DC block capacitor is required at input and output RF ports. The amplifier has built-in DC block capacitors at the input and output ports.

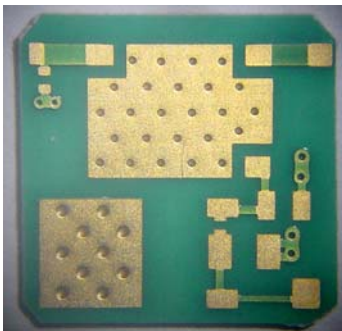

Fig. 1 Motherboard Sample

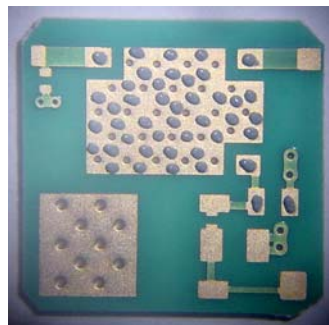

Fig. 2 Dispensed solder paste

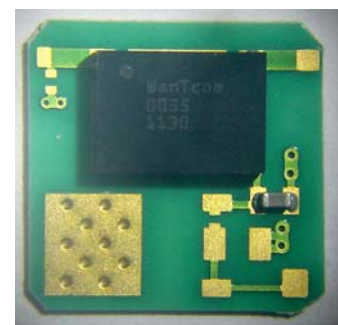

Fig. 3 Assembled part

B. Assembly

The regular low temperature and no clean solder paste such as SN63Pb37 is recommended. The high temperature solder has been used internally for the WHM series amplifier assembly. The melting temperature point of the internal high temperature solder is around 230 °C. Thus, melting temperature of the solder paste should be below 217 °C for assembling WHM series amplifier on the test board to reduce the possible damage to the amplifier. The temperature melting point of the SN63Pb37 solder paste is around 183 °C and is suitable for the assembly purpose.

For RoHS purpose assembly, the Bismuth based low temperature solder paste such as SN60Bi40 is required.

Regular RoHS solder paste SAC305 and its process will damage the amplifier!

The solder paste can be dispensed by a needle manually or driven by a compressed air source. **Fig. 2** shows the example of the dispensed solder paste pattern. Each solder paste dot is in the diameter of 0.005" ~ 0.010" (0.125 ~ 0.250 mm) range.

For volume assembly, a stencil with 0.004" to 0.006" (0.10 mm to 0.15 mm) thickness is recommended to print the solder paste on the circuit board.

Fig. 3 illustrates the assembled LNA on the motherboard.

For more detail assembly process, refer to AN-109 at www.wantcominc.com website.



C. Electrical Testing and Fine Tuning

The amplifier is designed to be fully matched at the input and output ports. Any tuning is not needed. However, when connecting the assembled amplifier to a device such as a SMA connector or a filter, the connecting points or joint points could affect mainly the return losses at the ports due to the non-ideal 50-Ohm impedance of the devices connected to the amplifier. By varying the connection feature size such as the solder amount to get the optimum return losses or best matching result at the interface. This fine-tuning has little effect on the other performance such as gain, noise figure, P_{1dB} , or IP_3 .

During the fine-tuning process, a vector network analyzer can be used to monitoring the return losses at the ports while varying the feature size of the joint points. Varying the connection feature size until the optimum return losses are achieved.
